

INFRA

Ductile Iron Tamper Proof Combination Air Valve
PN 10 , PN 16 & PN 25 Rating
DN 50 - 200 mm.



Innovative Flow Control Solution



Shree Krishna Industries

Manufacturers of all types of valves & fittings

An ISO 9001/2015 Company

H.O. & Works :

Office & Works : P-261/1, Benaras Road, Belgachia, Howrah-711108 (W.B.)

Foundry : P-282/1, Benaras Road, Belgachia, Howrah-711108 (W.B.)

Ph.: 033-2651-0077, Mobile : +91 91639 05657 / 9874445657

E-mail : skivalves@gmail.com, Website : www.infravalves.in

Branch Office :

Delhi | Mumbai | Chennai | Patna | Baroda | Bangalore | Ranchi | Hyderabad

Configuration

Combination Air Valve
(Single Chamber Triple Function Tamper Proof Type)

Description

The Combination Air valve has the features of both an Air release valve and an Air/vacuum valve. The Air release component is designed to automatically release to the atmosphere small pockets of air as they accumulate local high points along a pipeline when the pipe line or piping system is full and operating under pressure. The Air/vacuum component is designed to automatically discharge or admit large volumes of air during the filling or draining of a pipeline or piping system. The valve will open to relieve negative pressure whenever water column separation occurs. The valve is designed to suit the following three functions:- 1. Large orifice for venting of large air volumes on start up. 2. Large orifice for intake of large air volumes. 3. Small orifice for discharge of pressurized air during operation.

Application

As the system starts to fill, the Combination air valve functions according to the following stages:

1. Entrapped air is released by the valve.
2. Liquid enters the valve lifting the floats and sealing.
3. Entrapped air which accumulates at peaks along the system (where Combination Air Valves should be installed), rises to the top of the valve, which in turn displaces the liquid in the valves body.
4. The Float descends, peeling the rolling seal, the orifice opens and the accumulated air is released.
5. Liquid penetrates in to the valve, the float rises, rolling the rolling seal to its sealing position.

When internal pressure falls below atmospheric pressure (negative Pressure):

1. The float will immediately drop away from the orifice.
2. Air is admitted to the system.

Operation

The Air & Vacuum component, with the large orifice, exhausts air at high flow rates during the filling of the system and admits air at high flow rates during its drainage.

High velocity air, or even air mixed with a mist of water spray, cannot blow the float shut. Water entry will cause the sealing of the valve. At any time during system operation, should internal pressure of the system fall below atmospheric pressure, air will re-enter the system.

The Smooth release of air prevents pressure surges and other destructive phenomena. Admitting air in response to negative pressure protects the system from destructive vacuum conditions prevents damage caused by water column separation. Air re entry is essential to efficiently drain the system.

The automatic Air Release component, release entrapped air from peaks of pressurized systems where the valve should be installed.

Pockets of accumulated air may cause the following destructive Phenomena:

- Impediment of effective flow and hydraulic conductivity of the system, along with a throttling effect as would a partially closed valve. In extreme cases this will cause complete flow stoppage.
- Accelerate cavitation damages.
- High pressure surges.
- Accelerate corrosion of metal parts.
- Danger of high energy burst of compressed air.
- Inaccuracies in flow metering.

Features

- Reliable operation reduces water hammer incidents Dynamic Design allows high velocity air discharge; Preventing premature Closing.
- Lightweight, small dimensions, small and reliable structure.
- Special orifice seat design: combination of bronze and E.P.D.M rubber, assures long term maintenance free operation.
- The drainage outlet enable removal of excess fluids.
- Working pressure range 0.2-25 bar.

Automatic component

- Large orifice:
- Dramatically reduces the possibility of obstruction by debris.
- Discharges high air flow rates.
- Body made of high strength materials.
- All operating parts are made of specially select corrosion resistant polymer materials.

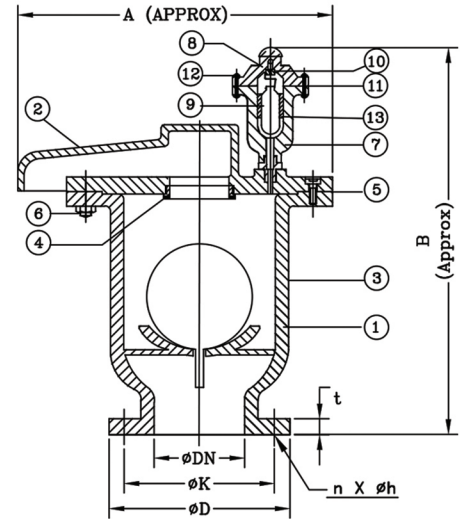

Technical Requirements

- Designed & manufactured according to standard of AWWA C-512
- The flange of the Air valve is according to IS 1538-93 (table-6) & also available as per BS EN 1092-2, DIN 2532/2533 & ISO 7005
- Pressure Rating - PN 10, PN 16 or PN 25 & Size Range of DN 50-200MM

Overall Dimensions

VALVE SIZE	FLANGE DIMENSIONS									WIDTH		HEIGHT
	PN10	PN16	PN25	PN10	PN16	PN25	PN10	PN16	PN25	A	B	
DN	øD	øD	øD	øK	øK	øK	n-øh	n-øh	n-øh			
50	165	165	165	125	125	125	4-19	4-19	4-19	240	390	
80	200	200	200	160	160	160	4-19	8-19	8-19	290	460	
100	220	220	235	180	180	190	8-19	8-19	8-23	340	490	
150	285	285	300	240	240	250	8-23	8-23	8-28	450	590	
200	340	340	360	295	295	310	8-23	12-23	12-28	470	620	

Material Specification

NO.	DESCRIPTION	MATERIAL	SPECIFICATION
KINETIC AIR VALVE (Low pressure—Large orifice—Air & Vacuum type)			
1.	BODY	Ductile Iron/ S.G. Iron	DIN 1693 Gr. GGG-40/50 IS:1865 Gr. 400/15 or 500/7
2.	COVER		
3.	FLOAT	Stainless Steel	AISI-304
4.	ORIFICE/NOZZLE	Neoprene/EPDM Rubber With bronze Impregnation	
5.	GASKET	Rubber	EPDM
6.	STUD & NUT	Stainless Steel/High Tensile Steel	
AUTOMATIC VALVE (High pressure—Small orifice type)			
7.	BODY	Ductile Iron/ S.G. Iron	DIN 1693 Gr. GGG-40/50 IS:1865 Gr. 400/15 or 500/7
8.	COVER		
9.	FLOAT	Stainless Steel	AISI-304
10.	ORIFICE & ROLLING SEAL	Bronze with rolling seal mechanism	
11.	GASKET	Rubber	EPDM
12.	STUD & NUT	Stainless Steel/High Tensile Steel	
13.	GUIDE	P.V.C.	-

Valves recommended for pipeline

Pipe Diameter	80-250	300-400	450-550	600-1200	1250-2400	Above 2400
Selected Air Valve	50MM	80MM	100MM	150MM	200MM	250/300MM

